

# Phase Three Charger Monitor/Control Unit

## INSTALLATION/OPERATION INSTRUCTIONS

### General Description

The Phase Three Charger Monitor/Control Unit (Model PT-MCU) provides the following:

- Digital DC voltmeter; reads DC system status to nearest 1/10th volt on up to three separate battery banks; provides local/remote high/low voltage alarm capability
- Output Voltage Adjustment Potentiometer (-4% to +5%)
- Double pole circuit breaker for local on-off control and AC over-current protection
- AC "ON" indicator light

It is designed for use with any of the following Phase Three charger models: PT-14, PT-25, PT-40, PT-70A, PT-24-8, PT-24-13, PT-24-20, PT-24-40.

### Installation/Wiring

*Note:* Installation requires removal of the cover (see Figure B for opened configuration). If the unit will be mounted in an area with limited access around the sides and/or top and bottom, the installer is advised to perform wiring *prior* to mounting.

- 1) Mount the PT-MCU on a bulkhead or other suitable metal or non-metal surface, as close as possible to the PT Charger. For ease of wiring and to use the power cord provided with the PT charger, it should be mounted within 5 feet.
- 2) Remove the four screws which secure the cover to the base of the unit (see Figure A).

**Figure A: Removing the cover**

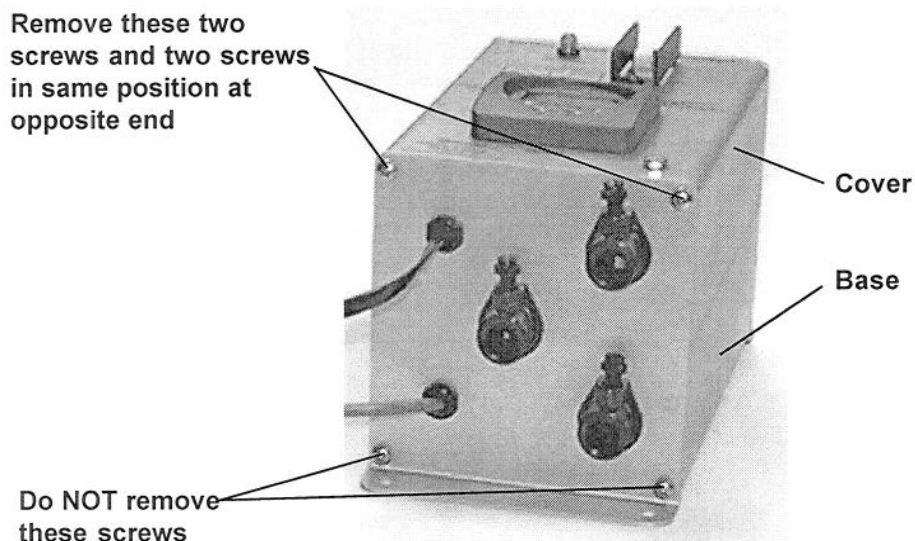

M-PT-MCU  
July 2003

#### U.S.A. HEADQUARTERS

P.O. Box 1306, Newport Beach, CA 92663  
Phone: 714-751-0488 Fax: 714-957-1621  
E-Mail: sales@newmarpower.com

**NEWMAR**<sup>®</sup>

**ELECTRONIC POWER PRODUCTS**  
COMMUNICATION • NAVIGATION  
[www.newmarpower.com](http://www.newmarpower.com)

#### EURO WAREHOUSE

Phone: +31-35-603-2494 Fax: +31-35-603-2149  
E-Mail: sales@newmarpower.com

- 3) Lift the cover and rotate away from base. *Caution:* Avoid putting strain on the internal wiring.
- 4) Re-secure the cover to the base in the open configuration with two screws as shown in Figure B.

**Figure B: Cover opened and secured**

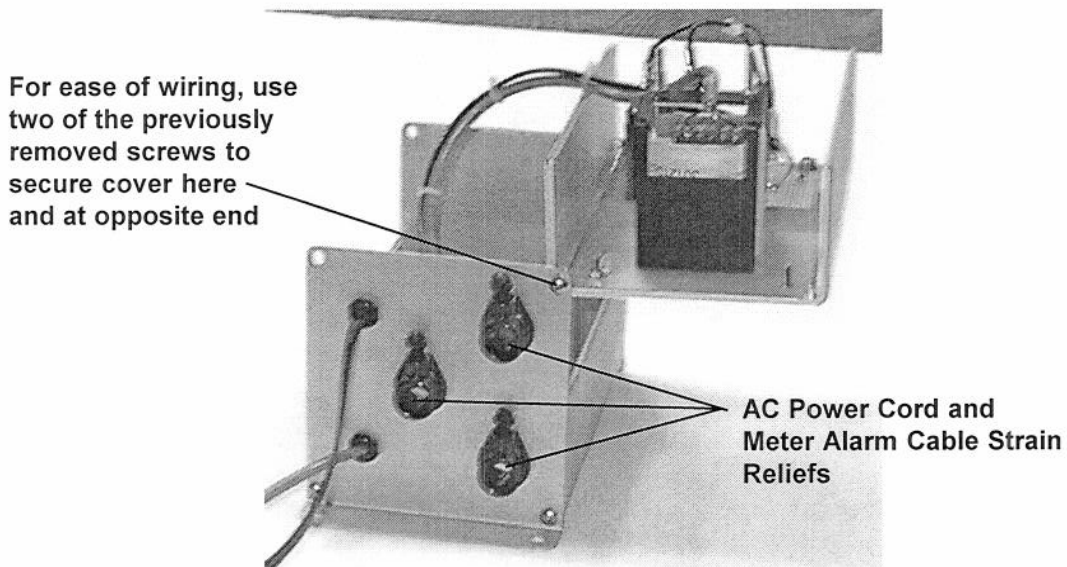

- 5) An AC power cord has been supplied with the Phase Three Charger (may already be factory installed, depending on model). The cord's three-prong plug is not used in this installation. Cut it off and push the end of the cord into the base through any of the strain reliefs. (See Figure B.)
- 6) Strip off the outer sheath about 6 inches, then strip and attach # 10 ring lugs to all three of the individual AC wires (hot, neutral, ground).
- 7) Route another installer-supplied cord from the AC power source, pass it through either of the remaining strain reliefs and repeat step 6. (Maximum cord diameter is .40".)
- 8) Remove the top nut and flat washer from the # 10 grounding bolt (location shown in Figure C on the following page) and attach the AC ground wires. For proper grounding contact, the two ring lugs must be sandwiched between the two flat washers.



**Figure C: Grounding and Circuit Breaker Wiring**

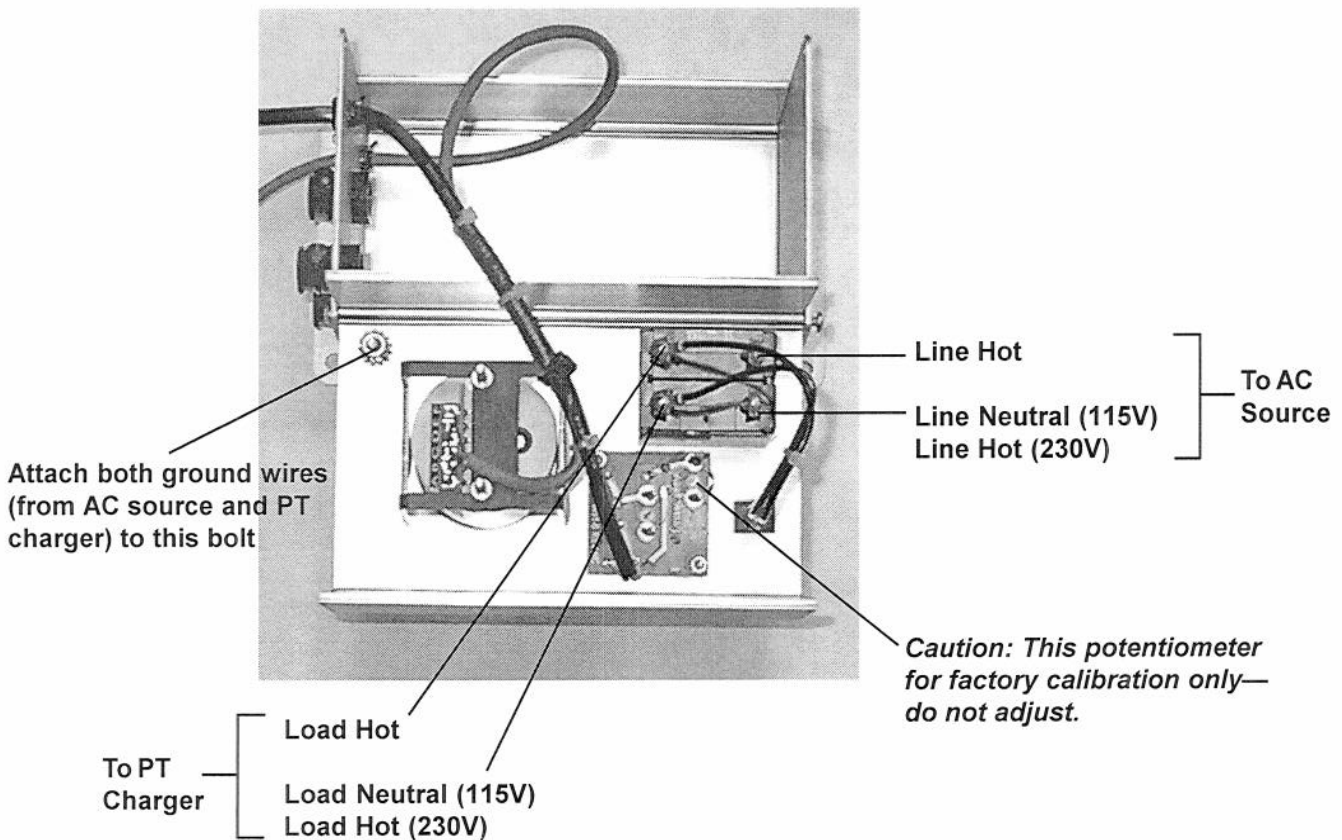

- 9) Attach the hot/neutral (115V installations) or hot/hot (230V) wires from the PT Charger AC cord to the *load* side of the circuit breaker as shown in Figure C. Be sure to replace the indicator light wires (factory pre-wired to the circuit breaker load side).
- 10) Attach the hot/neutral (115V) or hot/hot (230V) wires from the AC source power cord to the *line* side of the circuit breaker as shown in Figure C.
- 11) Option: If digital voltmeter remote alarming is required, use the remaining access port to route alarm wires to the meter. Refer to the provided DCV manual for alarm wiring and operation instructions.



**Figure D: Voltage Sense and Voltage Adjustment Wires**

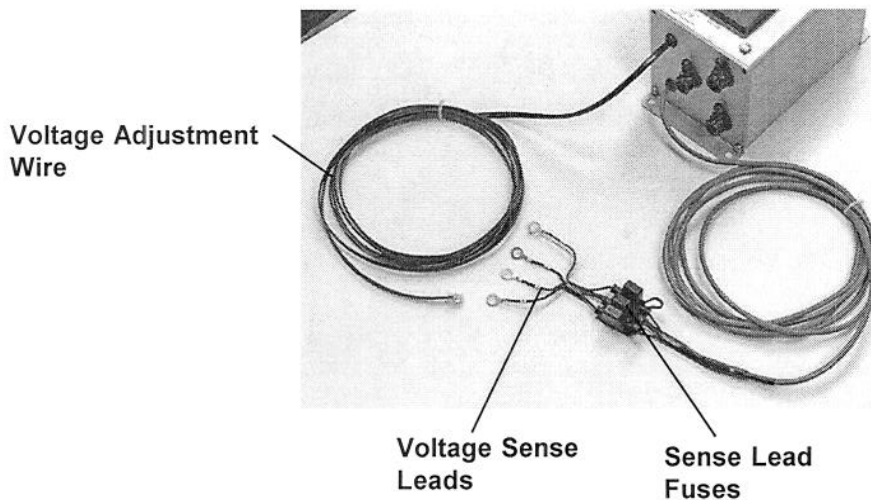

- 12) Remove the screws temporarily securing the cover and reassemble the unit.
- 13) Tighten the compression terminals on each of the cable strain reliefs.
- 14) Note that each of the voltage sense leads are labeled for proper connection to the charger (see Figure D). Attach the numbered "1", "2", and "3" leads to the corresponding (+) output terminals of the charger\*, and the "-" lead to the (-) COMM. terminal.

*\* Exception: For the voltmeter to function properly, all three (+) wires must sense a minimum of 9.6 VDC. If one or more of the charger banks are unused, connect the unused sense lead(s) to Bank 1 (+).*

*Note:* If batteries are already attached to the battery posts being wired to the PT-MCU, the Digital Voltmeter may make a loud "activation" beep upon contact of the sense leads. This is normal and may be disregarded.

*Fusing Note:* Each (+) sense lead is protected by an in-line 2 amp fuse. In the unlikely event one of these fuses should blow, it must be replaced with a BUSSMAN # ATM-2 fuse (or equivalent).

- 15) Connect the modular plug on the flat black voltage adjustment wire to the TEMP COMP jack of the Phase Three charger. *Do not connect it to the REMOTE MONITOR jack.* Note: Use of this manual voltage adjustment feature eliminates use of the charger's temperature compensation option, which automatically adjusts charger output voltage. *Do not use a phone jack splitter in an attempt to accommodate both manual and automatic voltage adjustment. Neither function will work properly in that case.*



## **Calibrating and Using the Digital Voltmeter**

Refer to the provided DCV Installation/Operation Manual under "Calibrating the Instrument".

*Note:* The DCV features optional-use, manually set backlighting. Because there is a direct electrical connection between the meter and the batteries, whenever the backlight is turned on it will continue to illuminate, even if the charger is switched off. Although the current draw is very small, batteries may eventually be drained if the backlighting is left on and the batteries remain uncharged for lengthy periods.

## **Adjusting Charger Output Voltage**

The output voltage of the PT charger may be adjusted upward or downward within a range of -4% to +5% of the nominal factory set voltage using the front panel potentiometer. It must be adjusted only when the charger is in the "float" mode and output is less than 2 amps. The nominal float voltage depends on model and gel-cell lead-acid switch settings as follows:

### 12 Volt Models

Gel-Cell	13.6 VDC
Lead-Acid	13.4 VDC

### 24 Volt Models

Gel-Cell	27.2 VDC
Lead-Acid	26.8 VDC

*Note:* Consult the battery manufacturer's instructions prior to making a change to the PT Charger's factory voltage settings. Verify that the charger is in the float mode putting out less than 2 amps by checking both the digital voltmeter on the front of the PT-MCU and the ammeter on the front of the charger. Then adjust the potentiometer up or down as necessary with a small flat tip screwdriver.

## **Circuit Breaker Control**

AC input to the charger may be switched on and off using the front panel 15 amp double pole circuit breaker. The front panel indicator light will illuminate whenever AC is being applied to the charger.



### **U.S.A. HEADQUARTERS**

P.O. Box 1306, Newport Beach, CA 92663  
Phone: 714-751-0488 Fax: 714-957-1621  
E-Mail: sales@newmarpower.com

**ELECTRONIC POWER PRODUCTS**  
**COMMUNICATION • NAVIGATION**  
**www.newmarpower.com**

### **EURO WAREHOUSE**

Phone: +31-35-603-2494 Fax: +31-35-603-2149  
E-Mail: sales@newmarpower.com



**Dimensional Drawings**

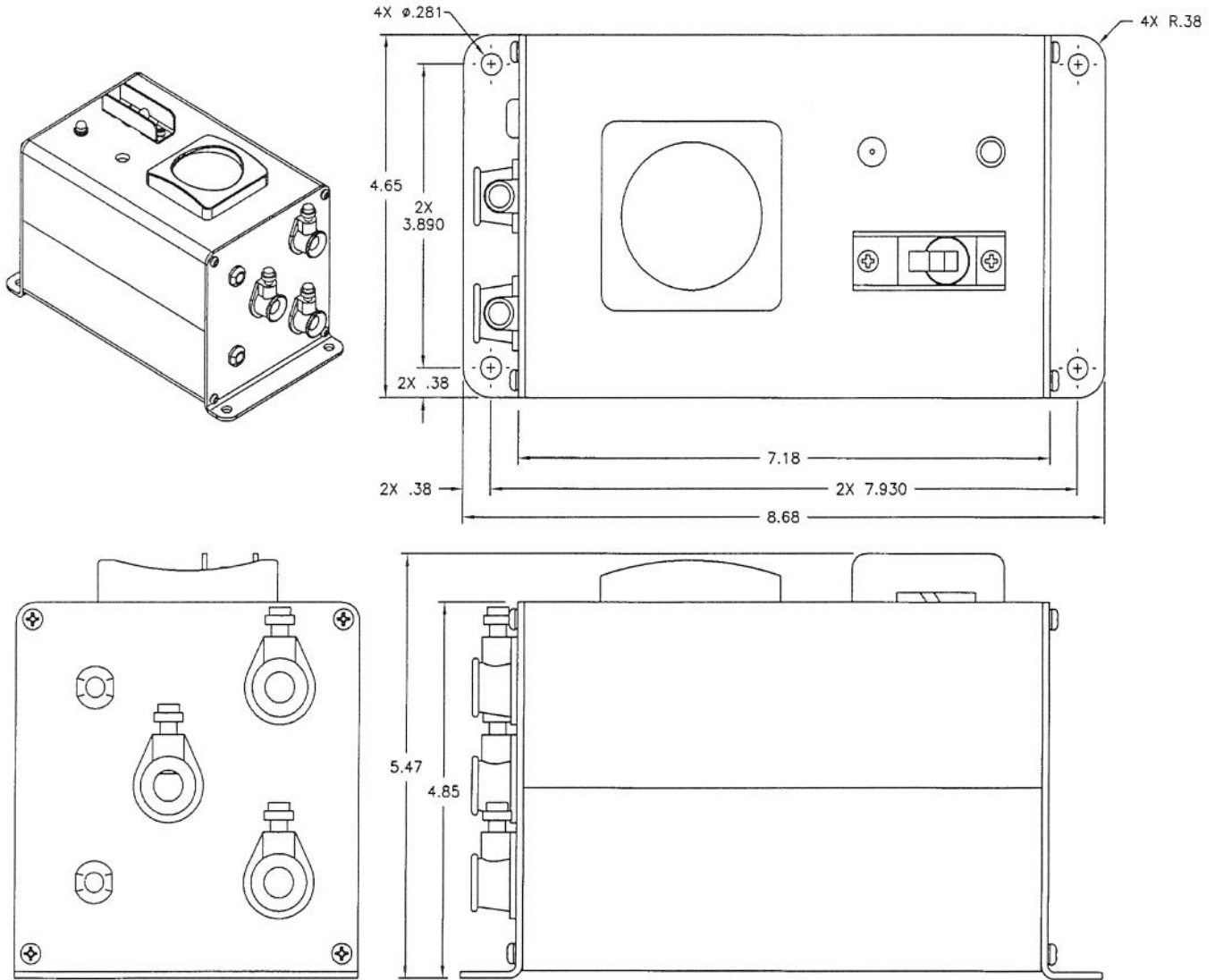

**U.S.A. HEADQUARTERS**

P.O. Box 1306, Newport Beach, CA 92663  
 Phone: 714-751-0488 Fax: 714-957-1621  
 E-Mail: sales@newmarpower.com



**ELECTRONIC POWER PRODUCTS**  
 COMMUNICATION • NAVIGATION  
[www.newmarpower.com](http://www.newmarpower.com)

**EURO WAREHOUSE**

Phone: +31-35-603-2494 Fax: +31-35-603-2149  
 E-Mail: sales@newmarpower.com